

VGrind 260

///// ROTARY TOOLS //

Grinding machine for the complete
machining of rotary tools with maximum
flexibility

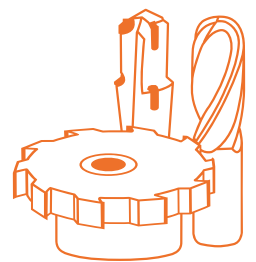

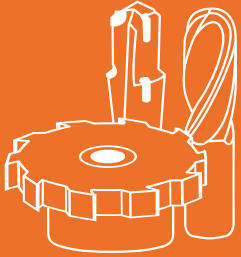

///// ROTARY TOOLS

DOUBLE SPINDLES FOR HIGH EFFICIENCY.

The **VGrind 260** has everything you could possibly need for the complete machining of your rotary tools. Ideal for sectors such as the automotive engineering, tool making, medical technology, precision engineering and aerospace industries.

The **VGrind 260** is equipped with tried-and-tested kinematics and a double spindle. Delivering precision multi-layer machining and the best thing about the **VGrind 260** is that you can configure the machine to meet your specific requirements.

From automation and coolant distribution to configuring the spindles and much, much more – configure your machine to work exactly how you want. The **VGrind 260** offers a new world of possibilities.



VGrind 260

INDIVIDUALLY CONFIGURABLE.

1 // MODERN OPERATING CONCEPT

Height-adjustable touch screen interface with 19" screen and ergonomic design for optimal view of the work area.

2 // WALL CONCEPT

Very rigid, compact construction with exceptional access and view of the work envelope.

3 // MULTI-LAYER MACHINING

Two vertically positioned grinding spindles with the grinding wheel at the C axis pivot point. Reduced machining times thanks to shorter linear-axis travel distances.

4 // INCLUDES IOT GATEWAY

The hot topic of Industry 4.0: Our machines are ready to communicate. An IoT gateway is installed as standard to provide central machine data acquisition.

5 // NUMROToplus®

Reliable and intuitive software platform with 3D tool and machine simulation that combines collision monitoring.

6 // GRINDING-WHEEL CHANGER

Provides greater manufacturing flexibility – with up to eight grinding wheel packages.

7 // AUTOMATION

The VOLLMER HP 160 pallet magazine, the HC 4 chain magazine, or the internal pallet loader automatically ensures increased capacity and flexibility.

// THE MACHINE CONCEPT

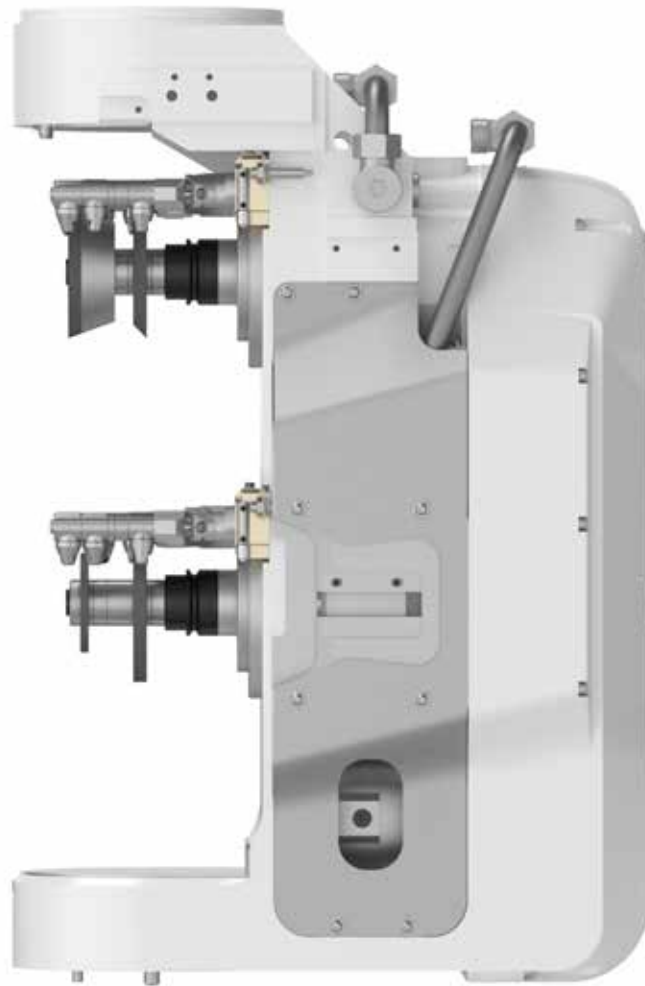

///// GRINDING WHEEL PACKAGES
are fixed to the C axis pivot point

The proven principle of vertically aligned grinding spindles has been brought to the **VGrind 260**. The efficient cooling concept has also been optimised. The result is perfection – the lowest tolerances with the most efficient cooling technology.

/// Five-axis CNC grinding machine with innovative kinematics

/// Two grinding spindles positioned one above the other with the grinding wheels positioned at the C axis pivot point – this ensures extremely precise grinding results

/// The two vertically positioned grinding spindles eliminate known concerns of using a floating bearing as opposed to a single spindle with two ends

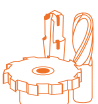



////// DOUBLE SPINDLE
for extremely precise grinding results

/// Innovative wall concept and polymer concrete base provide the highest possible rigidity and outstanding damping characteristics

/// The **VGrind 260** plate heat exchanger guarantees effective, long-term cooling of the motors and grinding spindles.
Even better – No additional chiller unit is required

/// Both grinding spindles can be equipped with a variety of grinding wheel packages.
The automation option ensures seamless grinding wheel changes, every time!



// THE MACHINE CONCEPT

OPTIONAL EQUIPMENT

/// Flexible automation options for rotary tools

/// Grinding spindle available with direct or belt drive

/// Automatic changing of grinding wheel packages complete with coolant elements for optimum productivity

///// WHEEL MEASURING PROBE
Grinding wheel measurements
and wear control



///// GRIPPER COMPENSATION
Safe, precise loading and unloading

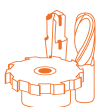

///// ROTARY TOOLS // MACHINE CONCEPT



//////// STICKING UNIT
for opening the abrasive coating

/// The automatic handling mechanism compensates positioning during the process to ensure maximum precision when loading and unloading tools and reduction sleeves. This reduces wear and optimises concentricity

/// The wheel measuring probe provides grinding wheel measurement and wear control all within the machine and process

/// Automated changing of intermediate sleeves with bayonet

/// Automatic sticking unit enables the grinding wheel to be opened during production

/// Simultaneous grinding wheel package and tool change in combination with the HP 160 pallet magazine or the HC 4 shortens non-productive times during loading

/// Stable, fully adjustable steady rest with automatic stroke ensures optimal grinding results



//////// STEADY REST WITH AUTOMATIC STROKE
ensures optimal grinding results
for longer tools

MAXIMUM PRECISION

///// For complete machining of tools.





/// THE APPLICATION

The *VGrind 260* has been designed for the efficient machining of rotary tools with different diameters.

The ability to change both grinding wheel packages and integrate a range of automation options provides the highest possible flexibility with reduced changeover times – perfect for flexible high-quality grinding.

For diameters up to 200 mm*

*For more information on the specifications, see page 15

// THE OPERATING CONCEPT

Thanks to its simplified, intuitive operation, the **VGrind 260** ensures that you always have everything under control. The height-adjustable desk features a clear LCD display, which is ergonomically positioned to provide operators with a good view of the work area at all times. During operation, you can choose to use the keyboard, touch screen or both – whichever is right for you.

The manual operating unit ensures even more flexibility: It can be freely positioned on the enclosure and is designed for setting individual axes – without using the control panel.

In short, the **VGrind 260** has been optimally designed with ergonomics and intuitive operation in mind – for your benefit. It makes it easy for you to achieve the best possible results.



///// ERGONOMIC OPERATION

Flexible, height-adjustable and tilting control desk, versatile manual operating unit, optimal view of the machine, simple access to the grinding spindles. It doesn't get more flexible than this.

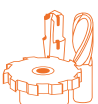



////// RELIABLE SOFTWARE SYSTEM
NUMROPlus®

// NUMROPLUS® SOFTWARE

VOLLMER consciously decided on a well-known system that is already established on the market. The logically structured interface guarantees intuitive operation. With an established programming system, a huge variety of tools can be manufactured and resharpener. You can change any detail of your tools and adapt them to your individual requirements.

Fully informed: with comprehensive 3D simulation of the tool and machine and with collision monitoring, you can be confident of complete process control.

- /// Develop
- /// Simulate
- /// Monitor
- /// Produce
- /// Measure
- /// Resharpen
- /// Document

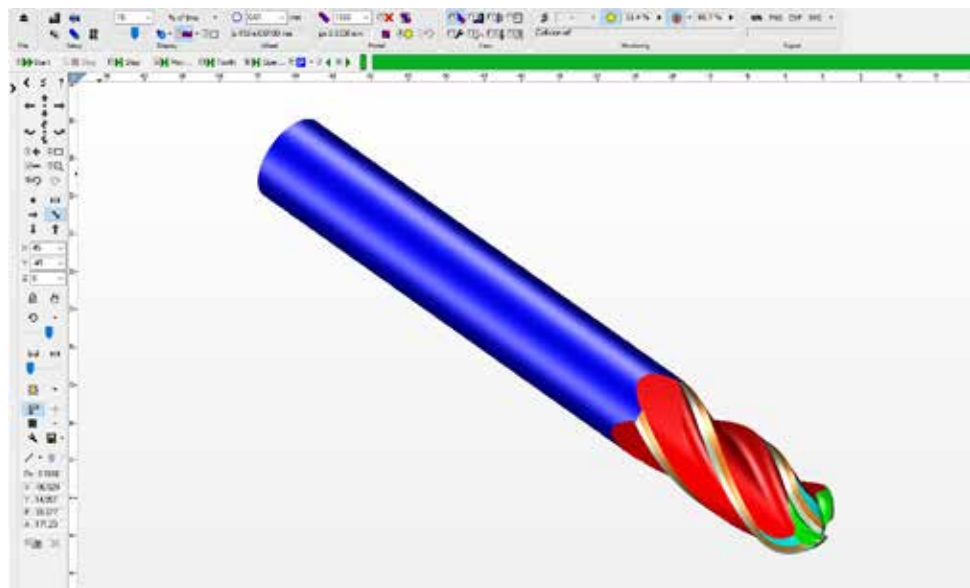

////// PROGRAMMING
of various tools

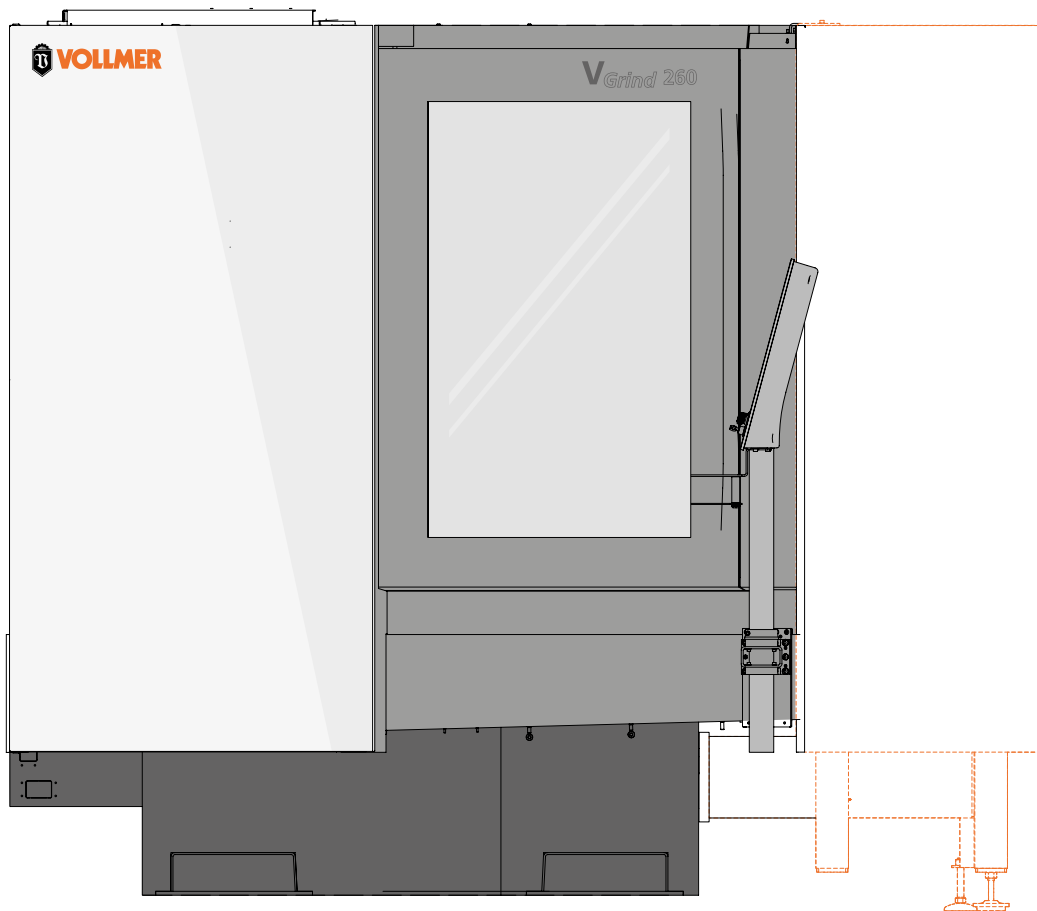

///// TOOL AUTOMATION
thanks to a range of automation options

// AUTOMATION

Work process automation is one of the key factors of modern tool machining. With the VGrind 260, you can choose from a range of excellent equipment options. This allows you to implement different batch sizes for your tools and make your manufacturing processes quicker, safer and more precise.

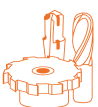

///// ROTARY TOOLS // AUTOMATION

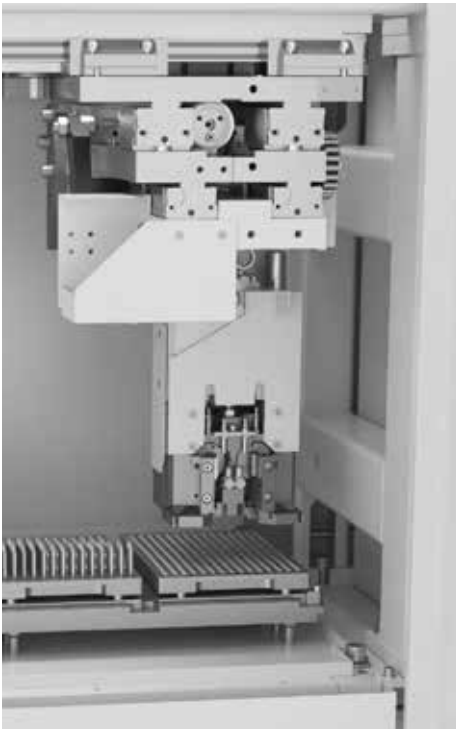

// TOOL AUTOMATION

The various automation options that we offer enable you to optimally adjust the *VGrind 260* to your requirements.

/// HP 160 pallet magazine with compact pallets (for up to 900 blanks or tools) and double gripper to guarantee quick changing times

/// The HC 4 chain magazine has space for 158 shank-type tools or, alternatively, up to 39 HSK-A63 tool holders in a compact design

/// Also available with an internal pallet loader to provide space for two compact pallets with a capacity of up to 300 blanks or tools. Alternatively, chaotic loading of different tool shank diameters is also possible

///// HP 160 PALLET MAGAZINE
for quickly supplying up to
900 blanks or tools

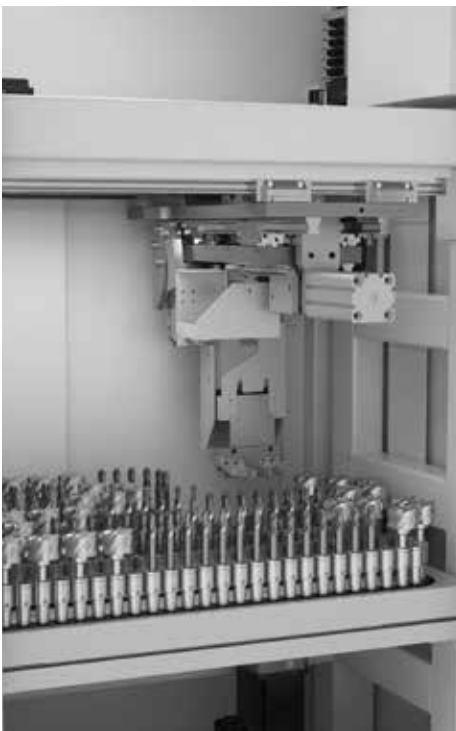

///// THE HC 4 CHAIN MAGAZINE
for 158 shank-type tools or up
to 39 HSK-A63 tool holders

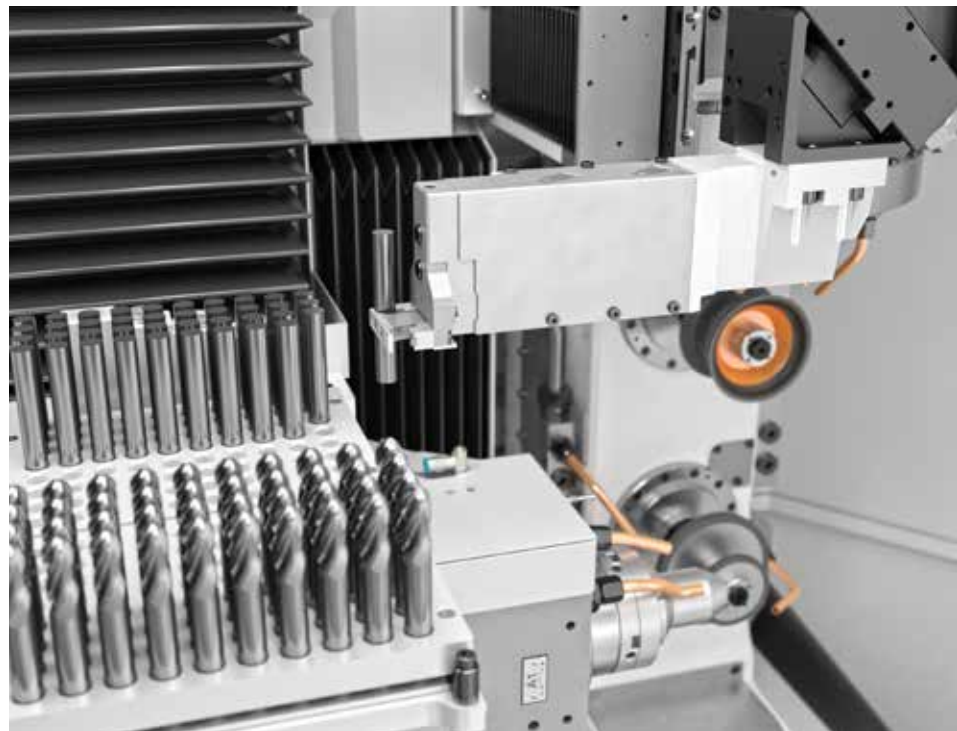

///// INTERNAL PALLET LOADER
with space for up to 300 blanks
or tools

// AUTOMATION

With the eight-station grinding-wheel changer, you automatically have the correct grinding wheel available. If required, this can also include interchangeable coolant elements on both grinding spindles. This helps to increase productivity in your manufacturing facility and reduce changeovers.

An oriented spindle stop function positions the grinding wheel packages in the same location on the grinding spindle. This reduces run-out errors and therefore increases precision.



///// EIGHT-STATION GRINDING-WHEEL CHANGER
for efficient grinding wheel changes and
reduction in non-productive time



///// EIGHT-STATION GRINDING-WHEEL CHANGER
including interchangeable coolant elements

// SPECIFICATIONS

TOOL

Outside diameter of up to 200 mm*
Tool length of up to 360 mm**

GRINDING WHEEL

Max. diameter of 150 mm***

GRINDING SPINDLES

	Belt spindle	Belt spindle	Motor spindle
Speed	10,500 rpm	6500 rpm	16,000 rpm
Drive output 100% duty cycle	11 kW	5 kW	10 kW
Peak power	23 kW	9 kW	20 kW
Torque	14 Nm	7 Nm	9.5 Nm
Spindle adaption	HSK50***	HSK50***	HSK50***

TRAVERSE RANGES

X1 axis	425 mm
Y1 axis	490 mm
Z1 axis	500 mm
A1 axis	360°, 450 rpm
C1 axis	Optionally 1000 rpm +15° to -200°

CONNECTED LOAD Approx. 18 kVA

WEIGHT Approx. 4900 kg net

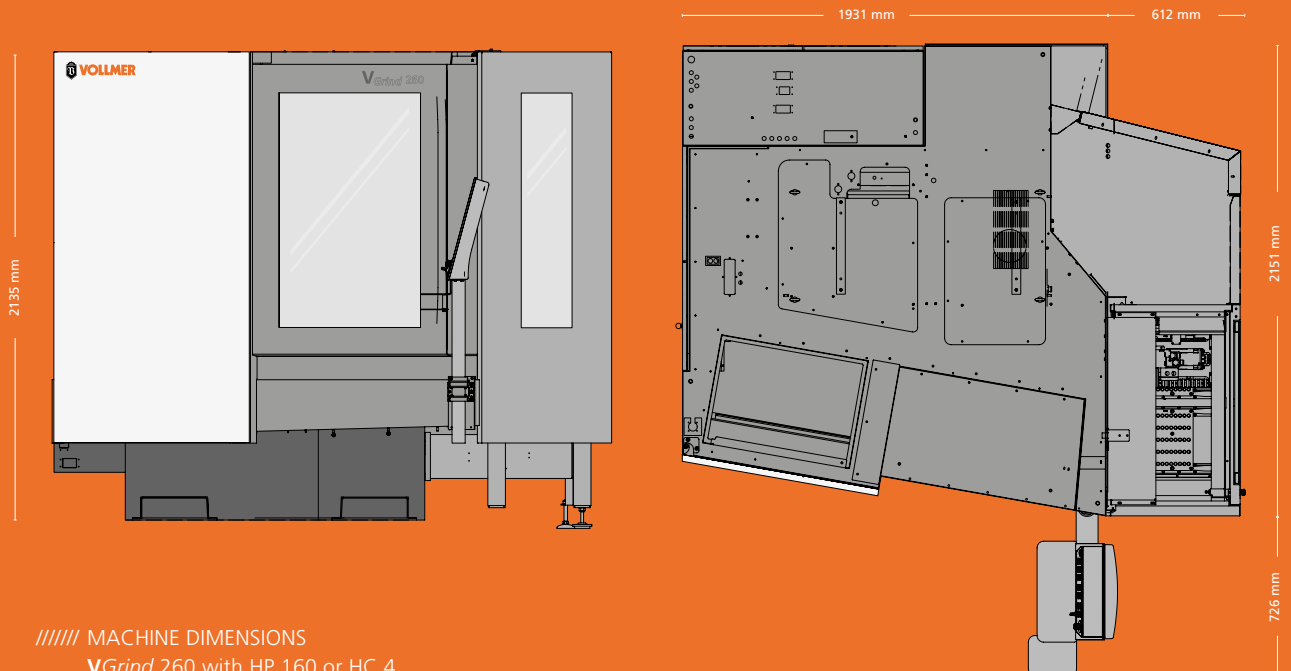

////// MACHINE DIMENSIONS
VGrind 260 with HP 160 or HC 4

We reserve the right to make design changes in the interest of technical progress. Patents pending.

*Depending on the specification, the machine kinematics may also allow for larger diameter tools.
**From the front edge of the workpiece carrier without measuring the cooling channel.
***Max. 125 mm with supporting device.
****Up to three grinding wheels per spindle end.



V@dison:

DIGITAL SOLUTIONS – PRECISION IN TRANSFORMATION

Do you want to optimise your processes with smart technologies, avoid mistakes and reduce downtimes? We offer you grinding and sharpening machines that are equipped with an IoT gateway as standard. Contact your VOLLMER representative or find out more now at:

www.vollmer-group.com/en/products/digitalisation

**VGrind 260 – THE MAIN ADVANTAGES
AT A GLANCE:**

/// INCREASED PRECISION

Innovative kinematics with multi-layer machining for maximum quality results. Benefit from uncompromising precision.

/// INCREASED EFFICIENCY

Shorter non-productive times thanks to intelligent and flexible automation. Experience productivity on a new level.

/// INCREASED USER CONVENIENCE

Make your work easier with good accessibility, ergonomically positioned control panel and reliable software.

/// INCREASED FLEXIBILITY

Efficiently machine tools with different diameters. For precision in the format of your choice.

315/en/800/04.22/Holzer